

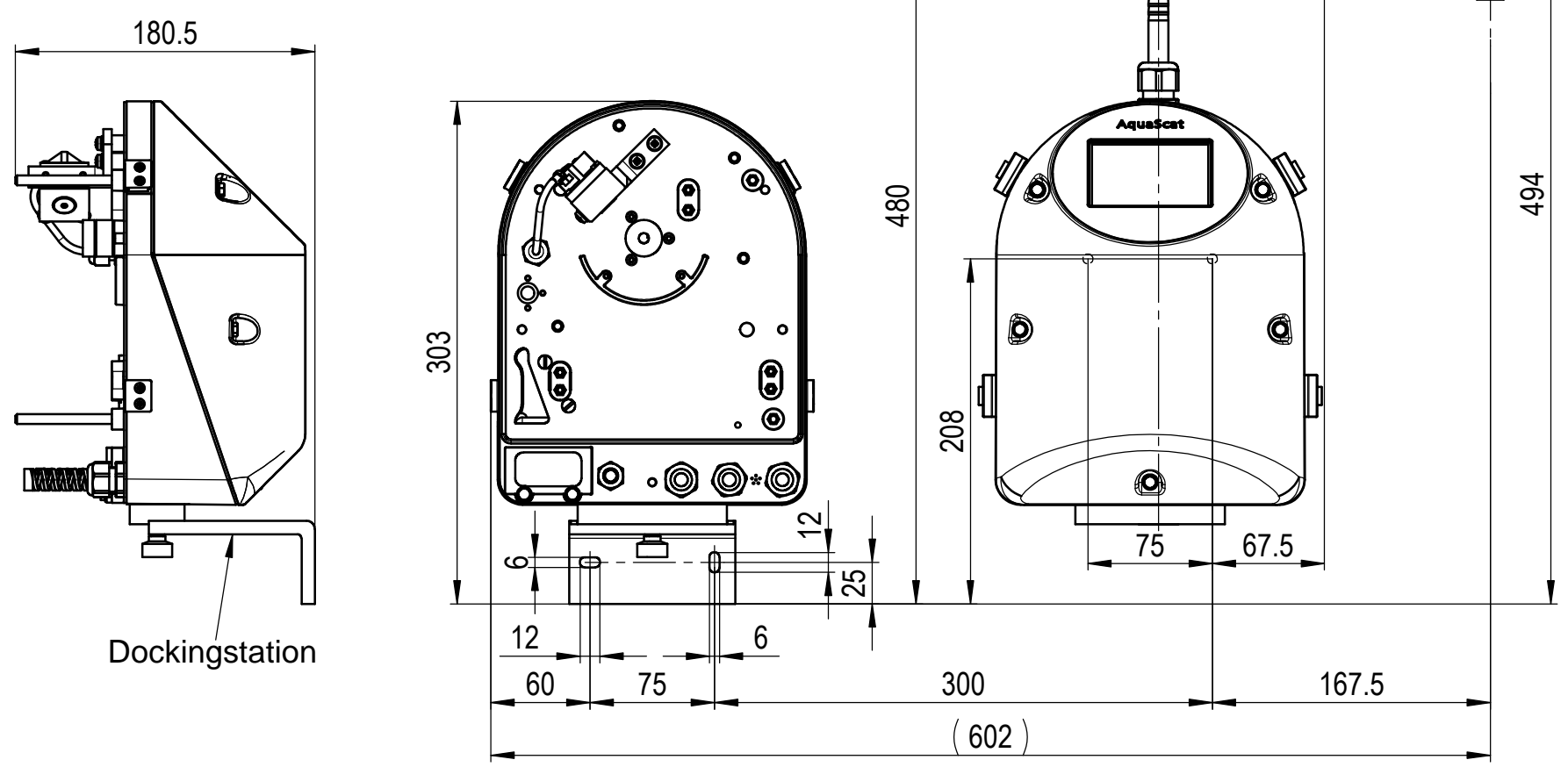

Montage Gerät für Wartung auf Dockingstation
 Mounting of instrument for maintenance on dockingstation



Massblatt AquaScat 2 WTM / WTM A / HT plan	Massstab 1:3	Datum	15.03.2012
		Geprüft	Phs
		Verteiler	
		Gezeichnet	Phs
 SIGRIST PROCESS-PHOTOMETER © SIGRIST-PHOTOMETER AG CH-6373 Ennetbürgen www.photometer.com Technische Änderungen vorbehalten. Subject to change without notice.		Zeichnungs-Nr. AQUASCAT2-MB	
		Index 1	